



DirectoValve® Electric Regulating Ball Valves

344B and 346B Pressure Regulating Ball Valves

The 340 series electrical regulating valves are designed to produce linear flow regulation and shutoff control in agricultural applications. Both models are available in several styles and motor speeds to accommodate different types of applications.

Features:

- Available in 2-way and 3-way versions.
- Available in 1, 3, or 6 RPM motor speeds. Note: The PR versions cycle time is double that of an R or RL version.
- Two-wire lead provides easy installation with 12 VDC systems.
- Low power consumption, less than 1 amp.
- Offered in a variety of inlet/outlet connections. See pages 96 and 97 for additional information and options.
- Wetted parts are Nylon, polypropylene, stainless steel, Teflon®, and Viton®.
- See pages 71–73 for additional information on B style motors.

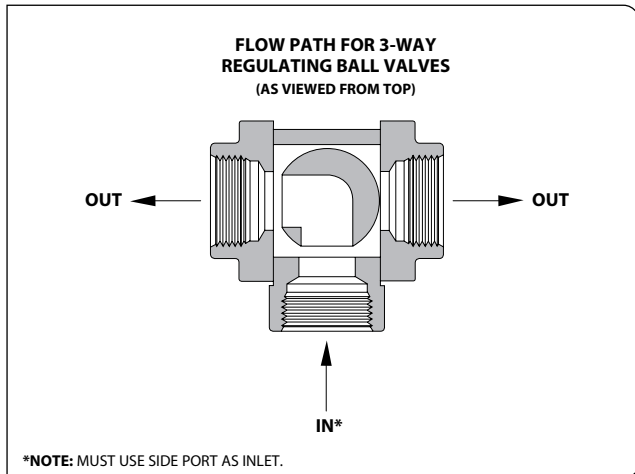

R & RL Series



344 BPR Series



346 R Series



346 BPR Series

Butterfly Valve

AA(B)244C-3/4 Remote Control Electric Regulating Butterfly Valve

The AA244C remote control electric regulation valve has been specifically designed to provide remote pressure control in agricultural applications using DirectoValve AA144A or AA145 solenoid shutoff valves.

Features:

- Unrestricted flow when wide open – 5 PSI (0.34 bar) pressure loss for 28.4 GPM (107 l/min) flow.
- Bypass flow rate: 2 GPM (7.5 l/min) @ 10 PSI (0.7 bar).

- Operates in 12 VDC system and may be controlled by a double-pole double-throw spring-centered switch.
- Maximum operating pressure of 100 PSI (7 bar).
- Two-wire lead for use in 12 VDC system.
- 3/4" (F) NPT or BSPT connections.
- Easy installation (flows either direction).
- Good corrosion resistance.
- Low current draw (0.10 AMP).
- 20 second response time.



How to order:
Specify model number.
Example: AA(B)244C-3/4
(B) = BSPT